



UNIVERSITÀ DEGLI STUDI DI NAPOLI  
FEDERICO II

itee<sup>PhD</sup>  
information technology  
electrical engineering



Hameed Ullah

Push-and-slide operations in contact  
inspection with an Unmanned Aerial  
Manipulator

Tutor: Fabio Ruggiero

Cycle: XXXVII

co-Tutor: ...

Year: 3rd Year

# My background

- MSc in Electrical Engineering (Specialization in Control), National University of Sciences and Technology, Islamabad, Pakistan
- DIETI Research group/laboratory: PRISMA Lab
- PhD start date – end date: 01/11/2021 – 31/10/2024
- Scholarship type: Marie-Sklodowska-Curie Innovative Training Network (ITN), Funded by EU
- Partner company : AEROTRAIN
- Periods abroad: 6 Months in DTU, Denmark

# Summary of study activities

- Ad hoc PhD courses / schools:
  - Field and Service Robotics
  - Robotics Lab
  - Robot Interaction Control
- International Training school:
  - 1st Training School on “Unmanned Aerial Systems for Inspection and Maintenance”, (University of Seville, Spain)
  - 2nd Training School on “Autonomous systems working in uncertain environments”. (DTU Denmark)
  - 3rd Training School (TS3) on “Training School on Field experimentation” (Lulea University of Technology Sweden)
- International Integration Weeks:
  - 1st Integration Week (IW-1) of AERO-TRAIN project: Tampere University Finland, Finland
  - 2nd Integration Week (IW-2) of AERO-TRAIN project: Eurecat, Centre Tecnològic de Catalunya, Barcelona, Spain
  - 3rd Integration Week (IW-3) of AERO-TRAIN project: CATEC (Advanced Center for Aerospace Technologies), Seville, Spain
- International Conferences attended
  - ICCC 2024, IEEE 25th International Carpathian Control, Poland
  - ICUAS 2024, International Conference on Unmanned Aircraft Systems, Greece.
- International summer school workshop
  - Summer School on “Multi-Robot Systems” Czech Technical University, Prague, Czech Republic
- Organized
  - Organized a workshop of AEROT-RAIN, at ICUAS 2024
  - Organized a summer school of AEROT-RAIN on Aerial Robotics, at ICUAS 2024, Greece

## Credits summary

PhD Year	Courses	Seminars	Research	Tutoring / Supplementary Teaching
1 <sup>st</sup>	24	6.2	41.8	0
2 <sup>nd</sup>	6	2.6	51.4	0
3 <sup>rd</sup>	4	2.0	46.8	0
<b>Total</b>	<b>34</b>	<b>10.8</b>	<b>140</b>	<b>0</b>

# Research area(s)

## Aerial Robotics:

- UAVs or Drone:
  - Application of Drones
  - Limitations
- Aerial Physical Interaction
- Aerial Manipulator (AM):
  - Drone + Robotic arm  
(Simple stick or Several DOF Robotic arm )
- “What”, Type of AM needed?
- “How” to control it?

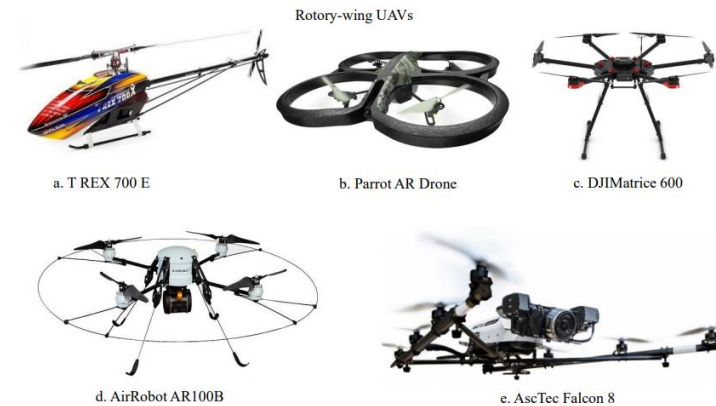
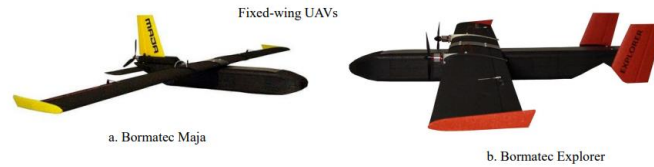

# Research results

- **Problem:**

- Complexity increase with DOF
- Controller design challenging



- **Objective:**

- To design a robust controller for AM
- Perform Physical Tasks
- Push and Slides Operation

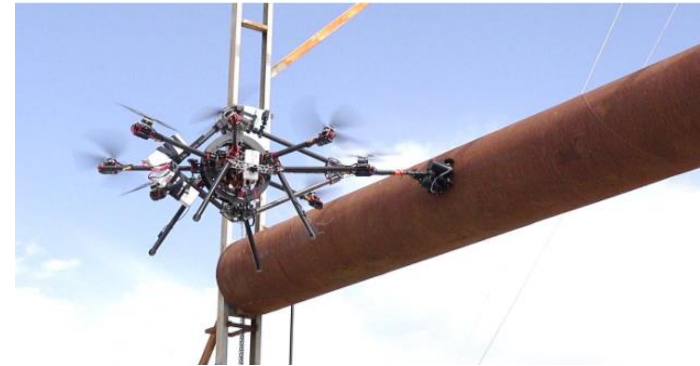

# Research products

[C1]	Hameed Ullah, D'Angelo, S., Ruggiero, F., Lippiello, V., & Soto, S. M. O. “ <i>Horizontal Sustained Force Delivery with an Aerial Manipulator using Hybrid Force/Position Control</i> ”, 25th International Carpathian Control Conference (ICCC) (pp. 1-5). Poland, 22-24 May 2024, IEEE. DOI: 10.1109/ICCC62069.2024.10569948.
[C2]	Hameed Ullah, S. M. O., Mazhar, N., Ahmad, I., Lippiello, V., & Ruggiero, F. “ <i>Pushing and Rotating a Heavy Mass Rigid Body Using an Omnidirectional Aerial Manipulator</i> ”, 6th International Conference on Robotics and Automation in Industry, ICRAI 2024, IEEE, (Paper Submitted)
[J1]	Hameed Ullah, Julien Mellet, Ruggiero, F., Lippiello, V., & Soto, S. M. O. “ <i>Interaction Control for an Aerial Manipulator Performing Two-dimensional Push-and-Slide Tasks</i> ”, (Work completed, expected submission to RAL).
[J2]	Hameed Ullah., Manuel J. Fernandez, Riccardo Franceschini, Antonia Hufner, Fernando Ruiz, Julian Cayero, Lionel Ott, Fabio Ruggiero, Anibal Ollero, Matteo Fumagalli “ <i>Assisted Aerial Inspection</i> ”, (work completed, expected submission to IEEE TRANSACTIONS ON FIELD ROBOTICS)
[J3]	Simone D'Angelo*, Hameed Ullah, Fabio Ruggiero, Bruno Siciliano. “ <i>Nonlinear Model Predicative Controller for aerial manipulator using to perform push and slide operations with constraints</i> ”. (work completed, writing phase, Journal is to be decided yet)



# Research products

[J4]	Mazhar, N., Khan, R., Raza, A., Malik, F. M., Azim, R. A., & Hameed Ullah. “Robust Decentralized Formation Tracking Control of Complex Multiagent Systems”. Complexity, 2024(1), 5088698. (2024).
[J5]	Shah, S. A. A., Gao, B., Ahmad, I., Hameed Ullah., Ahmed, N., & Saeed, A. (2023). “Adaptive backstepping integral sliding mode control for 5DOF barge-type OFWT under output constraint”. Journal of Marine Science and Engineering, 11(3), 492. (2023).
[J6]	Khan, R., Azim, R. A., Malik, F. M., Mazhar, N., Raza, A., & Hameed Ullah. “Fixed settling time control for self-driving car: two-timescales approach”. IEEE Access, 10, 36518-36537, (2022).
[C3]	Khan, A., Hameed Ullah., Faisal, U., Mazhar, N., & Khan, M. Y. “Visual-Inertial State-Estimation Using Ground Station for UAV”. In 2023 4th International Conference on Computing, Mathematics and Engineering Technologies (iCoMET) (pp. 1-6). IEEE. (2023, March).
[C4]	Raza, A., Mazhar, N., Malik, F. M., Khan, R., Khan, A., & Hameed Ullah. “Output Feedback Control of Two-Time-Scale Permanent-Magnet DC Motor Using High-Gain Observers”. (2023), Engineering Proceedings, 45(1), 20.
[C5]	Hameed Ullah., Owais Zarin, Malik, Irfan Ahmad, Sarfraz Ahmad, Ansar Abbas. “Robust Sliding Mode Control of a Quadrotor with Disturbance Rejection for Enhanced Stability and Performance”. International Conference on Robotics and Automation in Industry, ICRAI 2024, IEEE (Submitted).

# PhD thesis overview

## ■ Problem statement

### – Limitations of Underactuated UAVs

- **Underactuation** restricts **complex** (APl) tasks.
- **Insufficient controllable** DOF for **precise force** exertion.
- **Challenges** in tasks.

### – Aerial Manipulators (AM)

- Enhances **physical interaction** capabilities with the **environment**.
- **Issues** with **stable contact** and accurate **force estimation**.

### – Fully Actuated and OMAV

- Provide **six independently** controllable DOF
- Enable **decoupled** translational and rotational motions..
- Present **challenges** in modeling, and control strategies

### – State of the art

- Existing controllers **lack robust** and precise interaction **without added complexity**.
- Reliance on **additional sensors** increases **weight** and control difficulty



# PhD thesis overview

- **Objective**

- To design a robust controller that can stabilize the AM while APhI
- Development of advanced controllers:
  - Stabilized the system
  - To deliver controlled force while interacting
  - Large force delivery for long periods
- Development of AM:
  - AM design
  - Robotics arm design

# PhD thesis overview

- **Methodology**

- Aerial Manipulator design

- **Integration** of Active **Tilting** Mechanism Quadrotor/Octarotor
- Circular Shap end effector
- Novel 2D Omni Wheel Design
- Momentum-Based Wrench Estimators.

- Development of advanced controllers:

- Hybrid force/position control systems.
- Globally attractive hyperbolic controller.
- Nonlinear Model Predictive Control (NMPC).

- Impact and Applications

- Enhances **stability**, precision, and efficiency of AM.
- **Expands** applicability in **real-world** scenarios
  - Infrastructure contact inspection.
  - Push and slide operations
  - Environmental monitoring.

# PhD thesis

## Contribution 1:

### □ Horizontal Sustained Force Delivery with an AM using Hybrid Force/Position Control

- **Challenges:** Stabilized controller during physical interaction
- **Problem:** To deliver controlled force while interacting.
- **Methodology:** Hybrid motion/force control, with tilting rotor's Quadrotor
- **Achievements:** Large force delivery for long periods

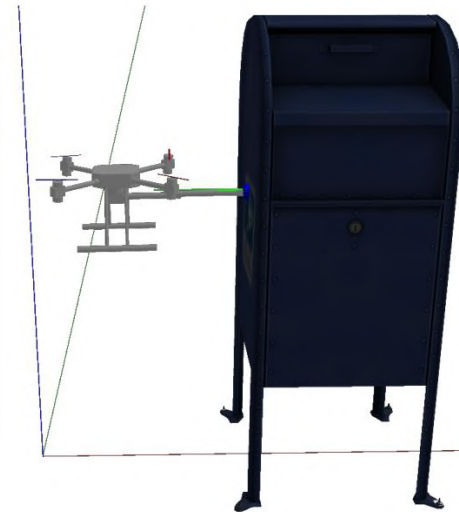
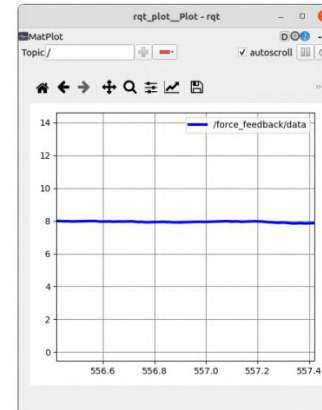
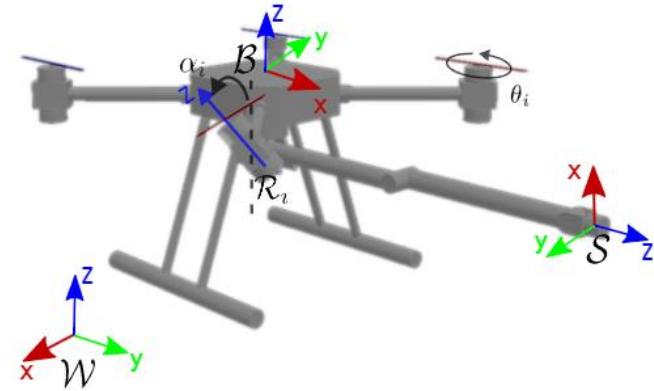

Aerial manipulator delivering an 8 N force to a rigid object.

# PhD thesis

- AM (Quadrotor + stick)
- Hybrid position/force control
- Force sensors
- Applied 1N, 2N, 4N, 6N and 8N of forces (Seccessfully Track)
- Gazebo Physical engine simulator (Robust Simulator)
  - Very closed to the real world implementation

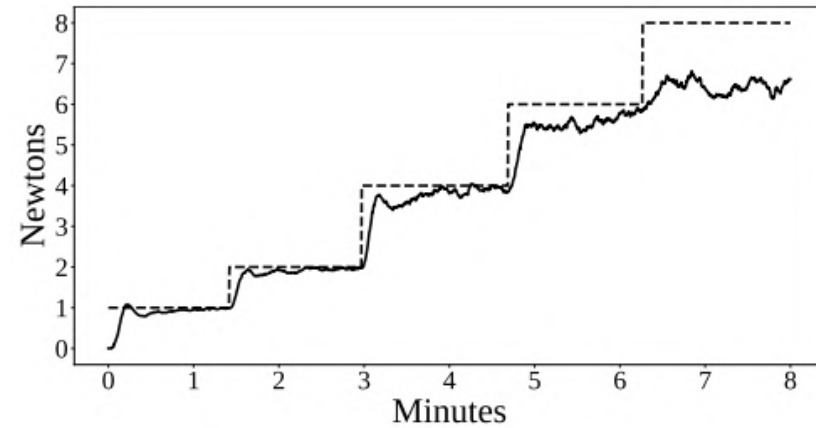

(a) State of the art

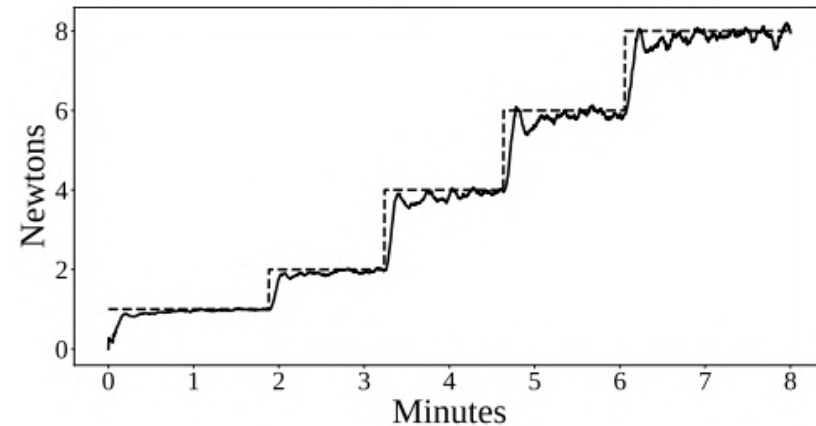

(b) Proposed

# PhD thesis

## Contribution 2:

### □ Pushing and Rotating a Heavy Mass Rigid Body Using an Omnidirectional AM

- Omnidirectional Octarotor
- Actively Tilted AM
- Circular End Effector
- Force Torque sensors
- Build the Heavy Mass Environment (20 KG)

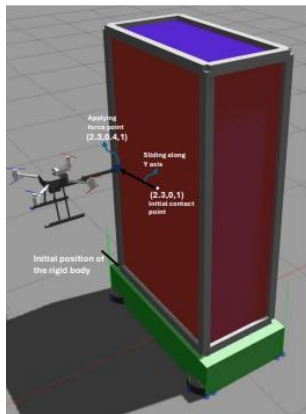
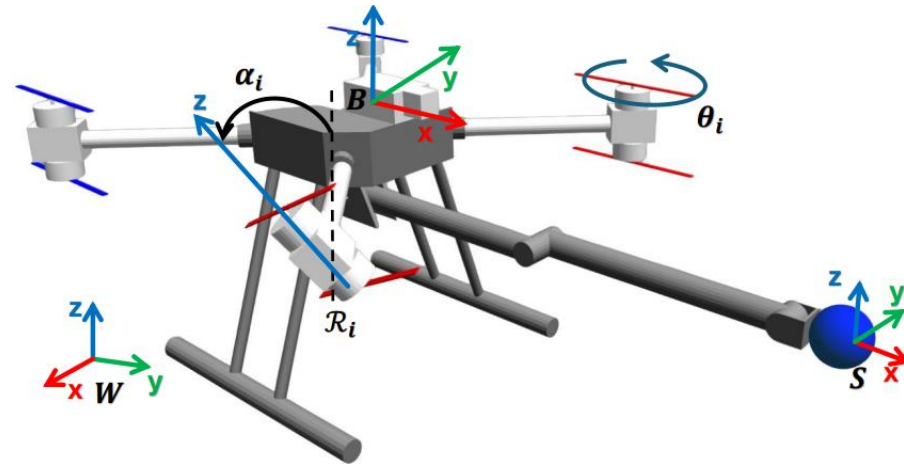

a. Aerial manipulator is in contact with heavy rigid mass, rotating from its one side

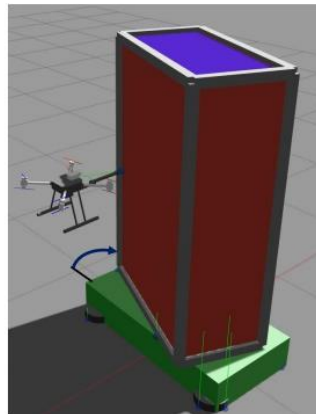

b. Rotating while applying less than 4N force

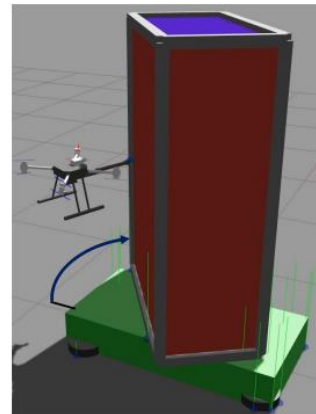

c. Rotating while applying more than 4N force

# PhD thesis

- Pushing and Rotating Heavy Mass (20KG)
- Figure a. 3D Plot
- Figure b. Applied Force (N)

Trajectory of rotating a heavy rigid mass

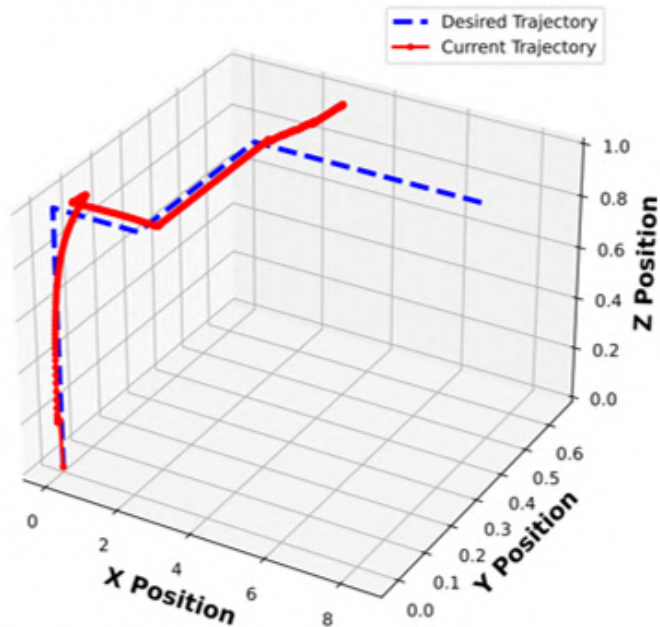

Comparison of Desired and Measured Force

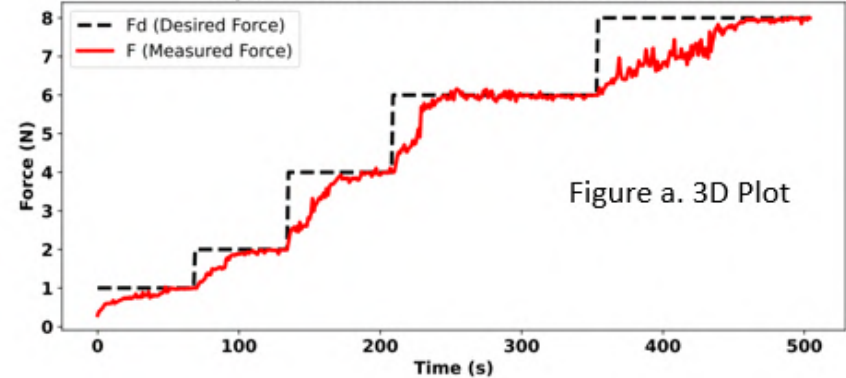

Figure a. 3D Plot



# PhD thesis

## Contribution 3:

### ❑ Interaction Control for an Aerial Manipulator Performing Two-Dimensional Push-and-Slide Tasks

- Novel 2D Omni Wheel
- Controller: Hyperbolic controller
- Momentum Base Wrench estimator
- 2D Pushing and Sliding
  - **Horizontal Sliding:** used wheel, **X-axis** motion
  - **Vertical Sliding:** used Roller **Y-axis** motion
- Various Trajectory Tracking

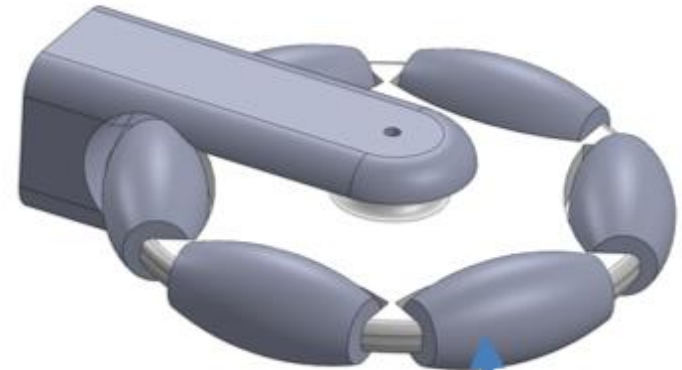

(b) Designed mechanism.

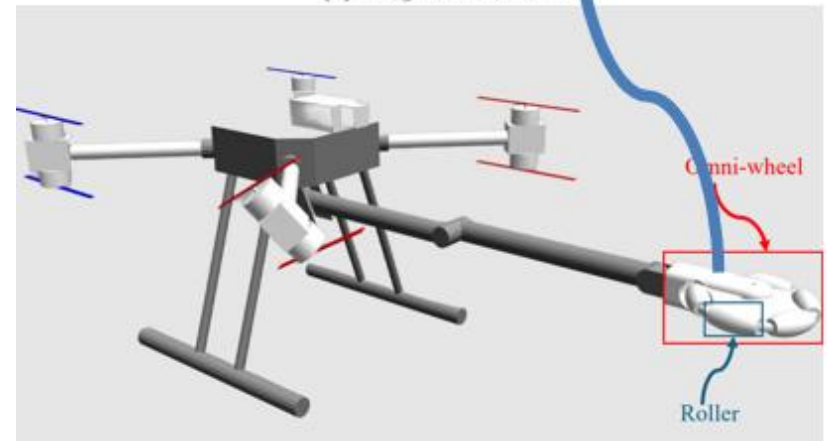

# PhD thesis

- Rectangular Trajectory Tracking
- Force estimation (MBE)(sensorless)

Rectangular trajectory tracking during sliding while in contact

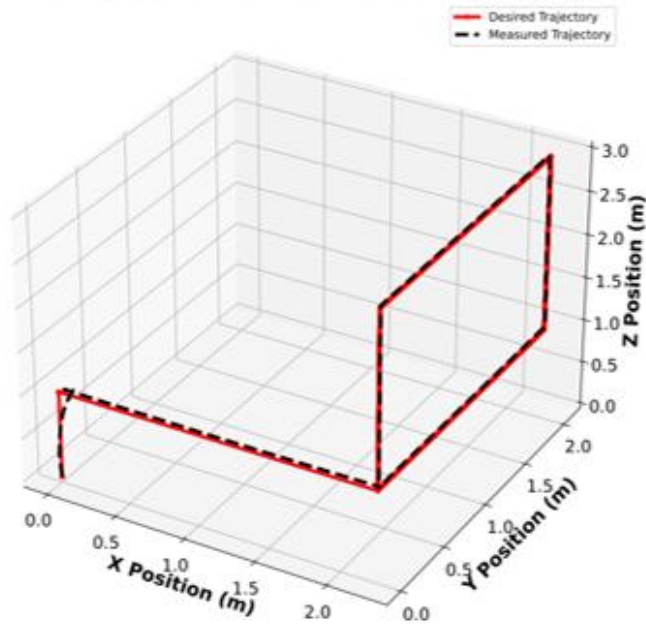

Applied force estimated

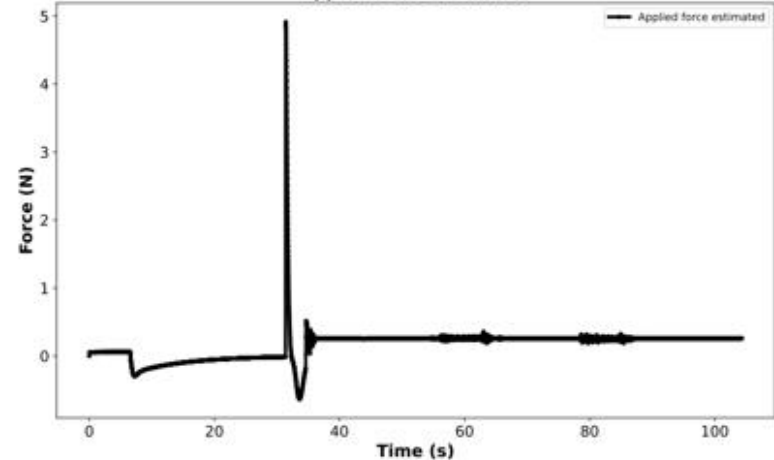

# PhD thesis

- Circular Trajectory Tracking
- Force estimation (MBE)

Circular trajectory tracking during sliding while in contact

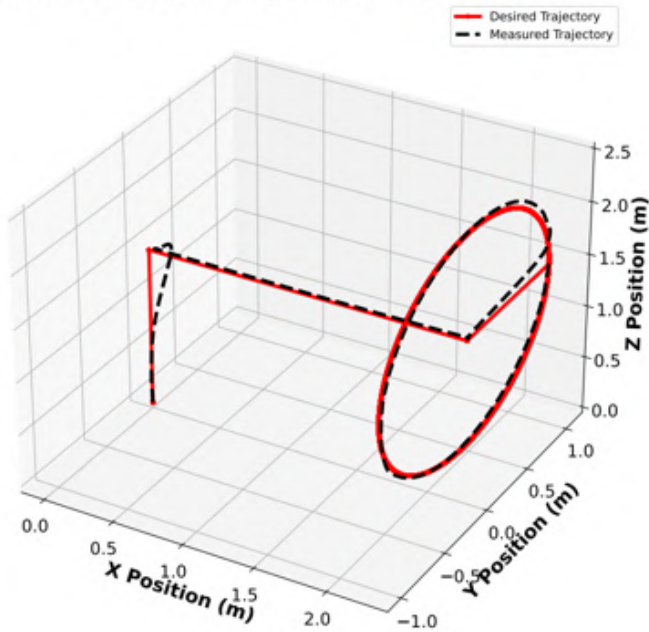

Applied force estimated

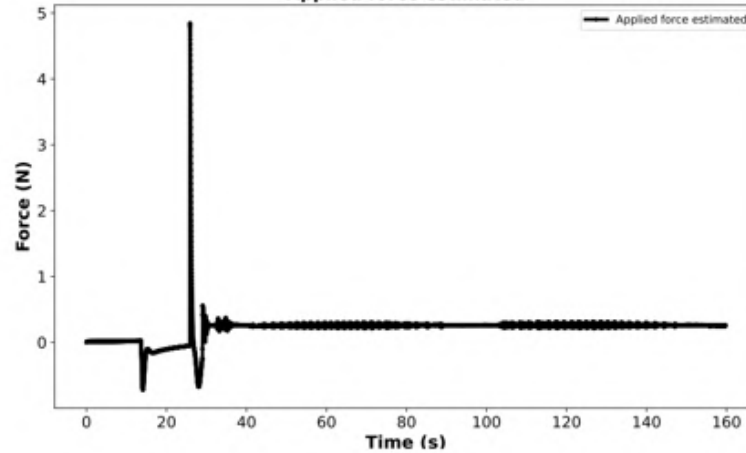

# AEROTRAIN Project

- Grand challenge: Application
  - Thanks to the project for the real testing platform
  - Nuclear Reactor Refinery (DTU Roskildi Campus, Denmark)
    - Container, Silo Tank and Pipes
  - Semi-autonomous, Prismatic manipulator stick,

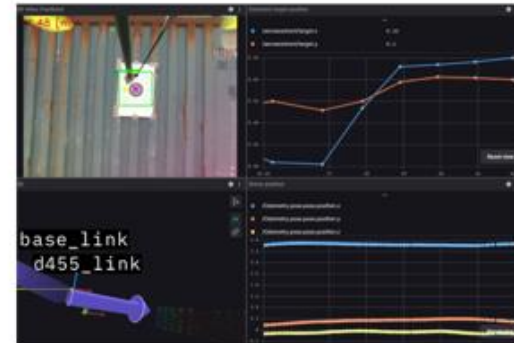

# Conclusion

- Addressed **challenges in APhI** using UAVs, focusing on precise control for physical tasks (e.g., infrastructure maintenance, disaster response).
- Designed a **hybrid controller** for aerial manipulators, achieving **superior force control**.
- Enabled **heavy object manipulation** (e.g., rotating 20 kg object) with **stable forces**.
- Introduced a **novel 2D omni-wheel** for push-and-slide operations, enhancing interaction dexterity **without traditional sensors**.
- This research lays a **foundation** for **future UAV applications** in industrial maintenance, search and rescue, and environmental monitoring.

*Thank you all for your  
attention*